



agria hispania, s.a.



**CARRETILLA ELEVADORA HIDROSTÁTICA
TH 210**



CARACTERÍSTICAS TÉCNICAS

MOTOR	Perkins 4 cilindros, 2200 cc. • 36,5 KW. • 50 CV. • Refrigerado por agua.
CAPACIDAD Kgs.	2.100
TRANSMISIÓN	Hidrostática Rexroth.
TRACCIÓN	4 x 4 con desconectador electrohidraulico con embrague.
VELOCIDAD	Lenta y rápida: desde 0 hasta 22 km/h. Sistema de aproximación lenta.
FRENOS	Hidrostático a las 4 ruedas, De servicio a las ruedas delanteras, de estacionamiento a las ruedas delanteras.
RUEDAS	11,50/80-15,3 y 10,0/75-15,3
PESO Kgs.	3.350
PENDIENTE SUPERABLE	38 %
OPCIONES MÁSTIL m.	Dúplex - Tríplex
RADIO DE GIRO mm.	Exterior: 4.450 / Interior: 2.950



TECHNICAL FEATURES

ENGINE	Perkins 4 cylinders, 2200 cc. • 36,5 KW. • 48 HP. • Water cooled.
CAPACITY Kg.	2.100
TRANSMISSION	Hydrostatic Rexroth.
TRACCIÓN	4 x 4 with electrohydraulic disconnection.
SPEEDS	Slow and fast: 0 - 22 Km/h, Inching Pedal slow approaching system.
BRAKES	Hydrostatic for 4 wheels, Service Brakes: Acting front wheels. Parking: Mechanic on front axle.
WHEELS	11,50/80-15,3 and 10,0/75-15,3
WEIGHT Kg.	3.350
SURMONTABLE SLOPE	38 %
OPTIONS MAST m.	Dúplex - Triplex
TURNING RADIUS mm.	External: 4.450 / Internal: 2.950

Dimensiones • Dimensions

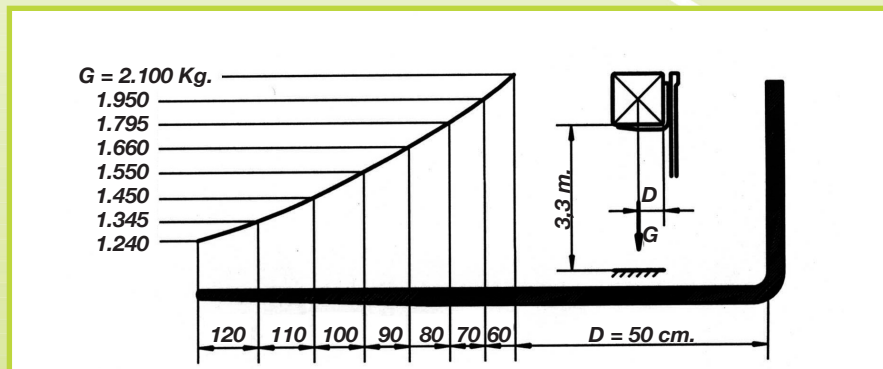

TH - 210	
H1	2.080
H2	Dúplex 3,14 m.: 2.250
	Dúplex 3,60 m.: 2.510
	Tríplex 4 m.: 2.080
	Tríplex 6 m.: 2.850
H3	200
L1	1.480
L2	1.700
L3	3.800
L4	1.700

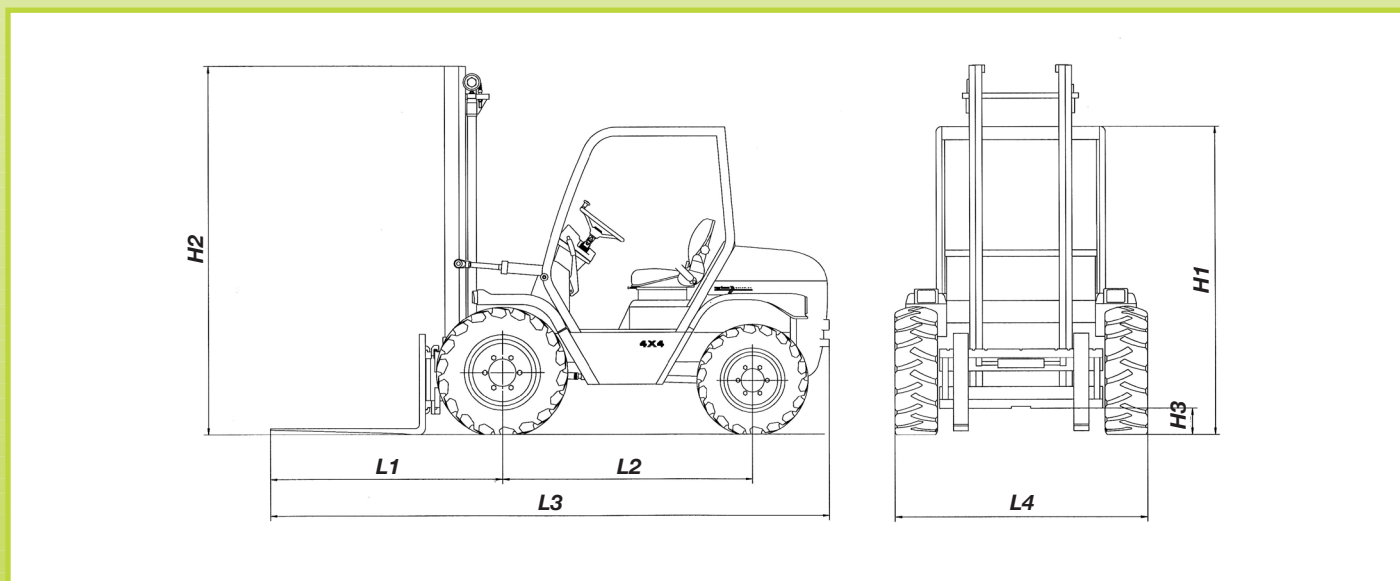

agria hispania, s.a.

Tel.: 94 630 00 55 • Fax: 94 630 01 34 • Apartado 26
E-mail: agria@agria.net • www.agria.net
48340 AMOREBIETA (Vizcaya) ESPAÑA

DISTRIBUIDOR: / DEALER: / DISTRIBUTEUR: